

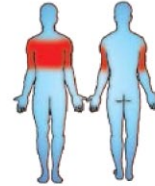

Unit Dimensions (mm) LxWxH : 2669x837x1557

## Safety Spacing

Area Needed: 5800mm x 3768mm

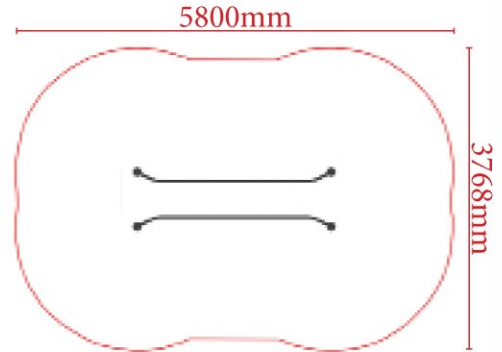

Certified by  
TUV to  
EN 16630

Suitable for  
users over  
1400mm tall.

Unit Free Fall  
Height:  
1414mm



You can use the Parallel Bars for tricep dips - a great way to develop strong triceps whilst also working on the chest area.

The workout Range features individual fitness stations which offer an environmentally friendly outdoor fitness facility. Each unit is designed to target a specific muscle group, creating a variety of activities which can create a full body workout or aid recuperation after accident or illness. Workout units are available in three attractive colour combinations : blue and silver, green and silver or red and yellow.

(Surface diagram to scale 1:100 on A4)  
(User diagram shows unit with a 1.8m tall adult)



Certificate Number 8101